

MAGNATECH

ORBITAL WELDING SYSTEMS

800 SERIES WELD HEADS

Models 810, 820, 830,
840, 860

Orbital Weld Heads
for Fusion Welding of Tube



*Use with all Magnatech
Power Sources*

800 Series Weld Heads

Orbital Weld Heads for Fusion Welding of Tubes

Precision Tools for Precise, Repeatable Welds

Magnatech introduces an entirely new line of easy-to-operate tools for autogenous tube welding. Four models with overlapping ranges cover tubes from 3mm to 152.4mm (0.125" - 6.0") O.D. Magnatech's 800 Series Heads make tube-to-tube and tube-to-fitting welds in less time with precision and repeatability.

The double-clamping design simplifies work piece fit-up and eliminates tack welding in many cases. Collets are available for any tube and fitting size.

Digital technology forever eliminates the need for periodic weld Head calibration - rotation speed remains accurate regardless of Head wear and Heads can be interchanged without time-consuming recalibration.



Superior Water Cooling Technology allows true 100% Duty Cycle

Applications

- High Purity • Pharmaceutical • Aerospace
- Sanitary (Hygienic) Process Pipe • Medical/Biotechnology
- Food Processing/Dairy • Brewery • Instrumentation



Features

- Collets for all tube sizes/fitting geometries
- Waterproof carry case standard
- Bench mount bracket
- Internal Weld Head cooling standard
- Convenient flip-up view port allows final inspection before welding
- Encoder motors provide precise, repeatable speed regulation
- "Jam" detection/protection. If rotation stops for any reason, it is instantly sensed and power to the motor is immediately interrupted. No more damaged motors or drive trains
- Standard 8m (25') hose pack length
- New rotation drive design tolerant of metal debris
- "Home" Position Switch automatically readies the Head for removal following weld-completion, and never requires adjustment
- Simple assembly makes field service straightforward



Molded silicone switch panel eliminates need for separate remote pendant. Dirt and moisture resistant.

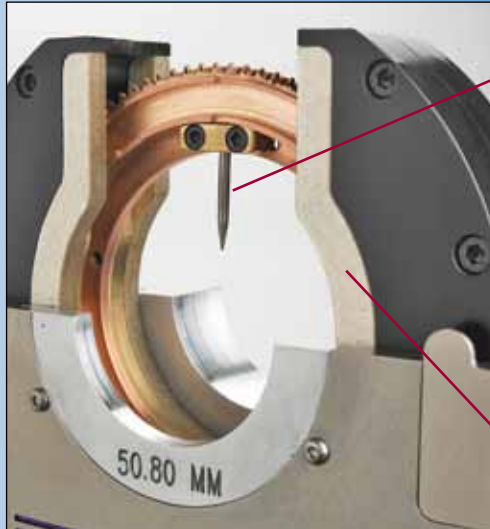

tungsten holder allows field replacement in a minute.

Virtual 360° circumferential contact of tungsten electrode guarantees positive arc starting.

The 800 Series utilizes two inexpensive insert plates made of a heat/UV resistant material to protect the Head housing and mechanism. If necessary, they can be replaced in minutes.



"Flip-top" hinges open for final inspection of tube alignment prior to welding.



Indestructible stainless steel hinge provides rigidity for positive tube alignment.



Vernier adjustments allow clamping force to be optimally set. Prevents deformation of thin wall tube.

Over-Center Clamping uses Solid Collets – Never Need Replacement*

- Flush collets for minimal axial clamping length
- Extended collets for maximum alignment capability

*Patent Applied For



Flush



Extended

Accessories

- Extension cables allow use up to 23m (75') from power supply
- Pre-ground tungsten electrodes
- Offset Tungsten Holders (Butt weld) allow use when axial clearance restrictions exist (such as short tangent fittings)
- Offset Tungsten Holders (Fillet weld) allow fillet (socket) welds to be made



Tungsten Electrodes

Specifications

Application	Orbital Autogenous GTAW welding of tube-to-tube, tube-to-fitting
Cable Length	8m (25') Standard. Extension cables available
Power Supply Compatibility	Tubemaster Models; Pipemaster Models

Dimensions/Weights

	Model 810	Model 820	Model 830	Model 840	Model 860
Tube Diameter Range	3–25mm (.125–1.0")	6–51mm (.25–2.0")	9–75mm (.375–3.0")	12–102mm (.5–4.0")	50–152.4mm (2–6.0")
RPM Range	0.6 – 9.5	0.3 – 5.0	0.1 – 2.5	0.1 – 2.3	0.1 – 2.0
Weight	3.2 kgs (7 lbs.)	5.0 kgs (11 lbs.)	6.4 kgs (14 lbs.)	8.2 kgs (18 lbs.)	10.0 kgs (23 lbs.)
"A"	124mm (4.90")	175mm (6.89")	202mm (7.96")	231mm (9.10")	297mm (11.71")
"B"	62mm (2.45")	83mm (3.26")	96mm (3.79")	110mm (4.31")	144mm (5.65")
"C"	42mm (1.64")	43mm (1.70")	43mm (1.70")	43mm (1.70")	43mm (1.70")
"D" ¹	19.5mm (.77")	19.5mm (.77")	19.5mm (.77")	19.5mm (.77")	19mm (.75")

¹ Distance from nearest flush collet face to tungsten centerline. (Tungsten offset from center)

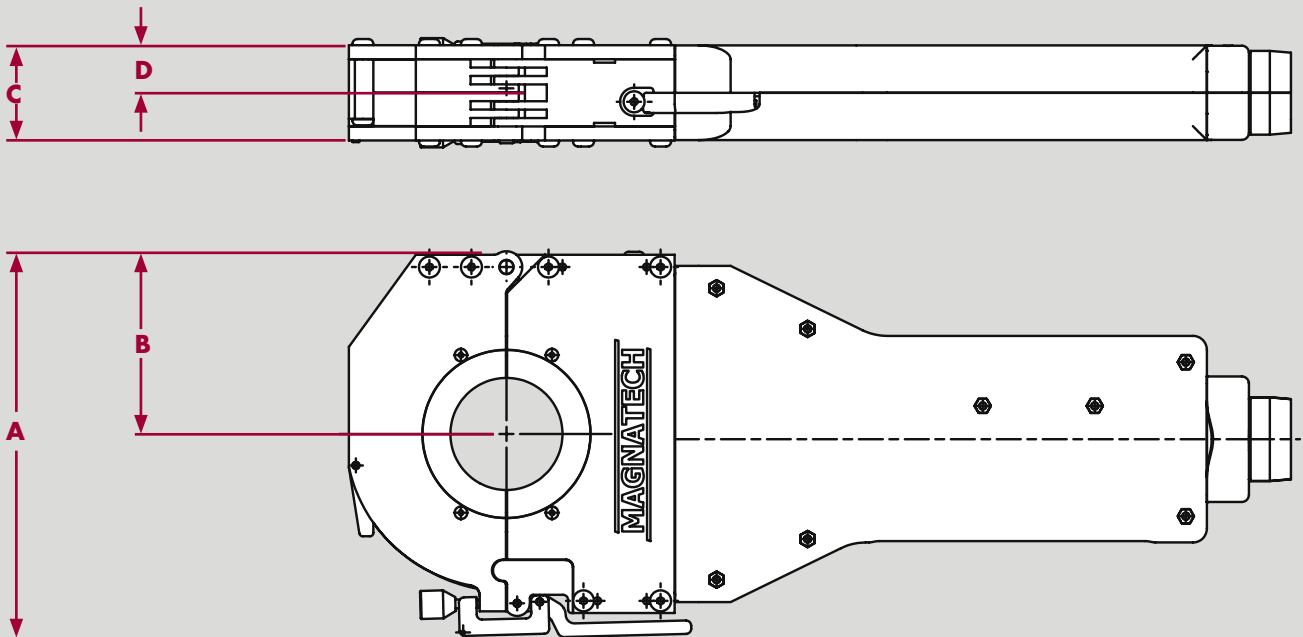

Represented By:

MAGNATECH

Headquarters: **MAGNATECH LLC**
 6 Kripes Road, P.O. Box 260, East Granby, CT 06026-0260
 Telephone: (+1) 860 653-2573 • Fax: (+1) 860 653-0486
 E-Mail: info@MagnatechLLC.com
 Web Site: www.MagnatechLLC.com

European Office: **MAGNATECH INTERNATIONAL B.V.**
 De Amer 24, 8253 RC Dronten, The Netherlands
 Telephone: (+31) 321 38 6670-79 • Fax: (+31) 321 31 4165
 E-Mail: info@Magnatech-International.com
 Web Site: www.Magnatech-International.com

W-93 6/11